

# MANUAL

## Installation and Maintenance Industrial Sliding Gate Operators DA500 - DA700 - DA200 - DA250

Manufactured in Australia



**E2913**

**Downee**  
Your perimeter solution partner

ABN 31 004 313 937

## SAFETY PRECAUTIONS

### **WARNING! FAILURE TO FOLLOW THESE SAFETY PRECAUTIONS AND INSTALLATION INSTRUCTIONS COULD RESULT IN INJURY OR DEATH AND/OR DAMAGE TO PROPERTY AND EQUIPMENT**

1. Read this installation manual thoroughly before commencing the installation of the equipment.
2. Check that the operator and controls have not been damaged in transit and are in new condition.
3. Ensure only appropriately licenced and competent personnel install the equipment.
4. The operators are designed to open and close sliding gates or doors only and should not be used for any other purpose.
5. Ensure adequate protection to people and property against the effects of shearing, compression and other traps which could cause serious injury or death, it is **essential** to undertake a risk assessment of the gate or door and its associated support posts and walls. **Consideration must be given to ensure safe operation of the general installation and surrounding environment.**
6. Check that the foundations, gateposts, and mounting structures have the necessary strength and rigidity to support the operator and the gate both when stationary and whilst in motion.
7. Erect safety signs to indicate any danger areas and automatic operation of the gate or door.
8. The operators are NOT designed for use in hazardous areas (flammable/explosive atmospheres) or areas subject to flooding, etc.
9. All electrical connections and wiring must be performed in accordance with all applicable local laws.
10. It is the responsibility of the installer to ensure the safety of the automatic gate system. A health and safety risk assessment must be performed on the automated gate system, and appropriate mitigants must be provided.
11. Do not allow children to play with fixed controls. Keep remote controls away from children.
12. Activation of the manual release may cause uncontrolled movement of the driven part due to mechanical failures or an out-of-balance condition.
13. Frequently examine the installation for imbalance where applicable and signs of wear or damage to cables, springs and mounting. Do not use if repair or adjustment is necessary.
14. Disconnect the supply(s) when cleaning or other maintenance is being carried out.
15. DA Operators exceed a single person lift, and weigh in excess of 65kgs. Please adopt safe manual handling techniques when lifting, manoeuvring, and positioning these operators into their respective locations.

16. Care must be taken to avoid entrapment and the creation of unsafe cavities that may be created between the gate and any adjacent receiver posts, fences, walls etc. A risk assessment should be carried out to determine if any safe guarding is required to avoid potential entrapment hazards at the installation site.

17. **Always incorporate the appropriate strobes, photoelectric beams, induction loops, bump strips and any other appropriate safety devices to protect both equipment and personnel.**

**EXTRA caution should be employed when using the operator in auto-close mode.**

## WARNING

### Notice of Compliance

AS/NZS 60335.2.103:2016

Household and similar electrical appliances – Safety

Part 2.103: particular requirements for drives for gates, doors and windows.

To comply with the above Standard, this operator must be connected using the inbuilt monitored PE beam circuit.

The monitored circuit is an option within the Elsema MCI control board.

Details on how to enable this option can be found within Menu 3 - Input Functions of the Elsema control board.

A 10K resistor (supplied with this operator), must be connected to the PE beam circuit, as outlined in the schematic diagram below:

#### ELSEMA MCI Board - Monitor PE Wiring and Programming Guide 1

##### Menu 3.1 - Photoelectric Beam Polarity - select Monitored PE Beam

The photocell with the resistor needs to be located on the gate receiver post (being the photocell furthest from the motor)

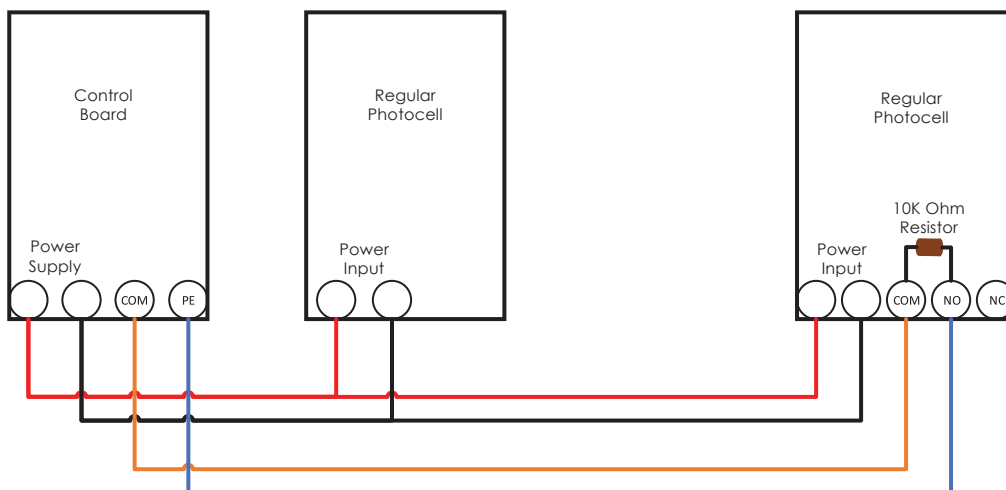

## WARNING: ELECTRICITY CAN KILL

The manufacturer of the automation equipment is not responsible for the damage which may be caused to either the operator, gate or door and any other person or equipment when:

- The steps in this installation manual and good installation practices were not followed.
- Faulty, inadequate, or insufficient safety devices were used.
- The gate or door, its support structures, or its accessories, are not sufficiently strong or rigid to be driven by the installed gate operator.
- Locking devices were insufficient or not installed where they were necessary. Gate locks may be necessary in some applications to prevent the gate from being forced open, which can damage the operator.
- Maintenance has not been performed at the specified intervals, or that maintenance has not been performed to a reasonable standard.
- Any other circumstances beyond the manufacturer's control.

### Post Installation

- Isolate the power to the gate operator before attempting any maintenance.  
**Warning the gate operator contains power electronics which may remain energised after power has been isolated. Ensure the system has been de-energised before attempting any work on the operator.**
- Only suitably qualified personnel may carry out maintenance.
- All electrical connections 240V or above must be performed by a suitably qualified and licenced electrician.
- Only original spare parts are to be used.
- The installer is responsible for providing all information concerning the safe use of the automation equipment as well as instructions regarding the manual override and maintenance procedures to all users of the system.

## PRODUCT DESCRIPTION

### Technical Data

	DA 500	DA 700	DA 200	DA 250
Input Voltage (V~)	230-240			
Rated Supply Current (A)	2	3	2	3
Absorbed Motor Power (W)	550	750	550	750
Maximum Opening Speed (mm/sec)	500	700	200	250
Approximate Pushing Force (N)	1,150	1,200	1,500	1,950
Maximum Gate Weight (kg)	1,200	2,000	1,500	3,500
Maximum Gate Length (m)	11.5	13.5	11.5	13.5
Maximum Duty Cycle (%)	100			
Operating Temperature Range (°C)	-10 to +40			
Weight of Operator (kg)	70	75.5	70	75.5
Auxiliary AC Power Supply Output	24VAC 2.5A			
Auxiliary DC Power Supply Output	12VDC 500mA			

\*Note: Maximum gate length specified is based on standard limit switch configuration. Limit switch variations are available to accommodate longer gate lengths.

### Foundation

The gate operator requires a flat and structurally sound foundation to mount the operator. The foundation should be appropriate to support the gate and the loads the operator will apply to drive it. The foundation must also be sufficient for the fasteners used but must extend a minimum of 100mm beyond each edge of the operator's base.

### Wiring Requirements

- Single phase 240VAC 10A earth-leakage protected power close to where the operator is mounted.
- Extra low voltage cables from the gate operator to connected accessories, i.e. safety, and access control systems. Extra-low voltage cables must be shielded if they are longer than 8m. Cable shields must be connected to ground.
- Conduits for power and accessories should come up through the base plate 'knockout'.

## PLAN VIEW LAYOUT / CONDUIT POSITION

### DA500 / DA700 Plan View

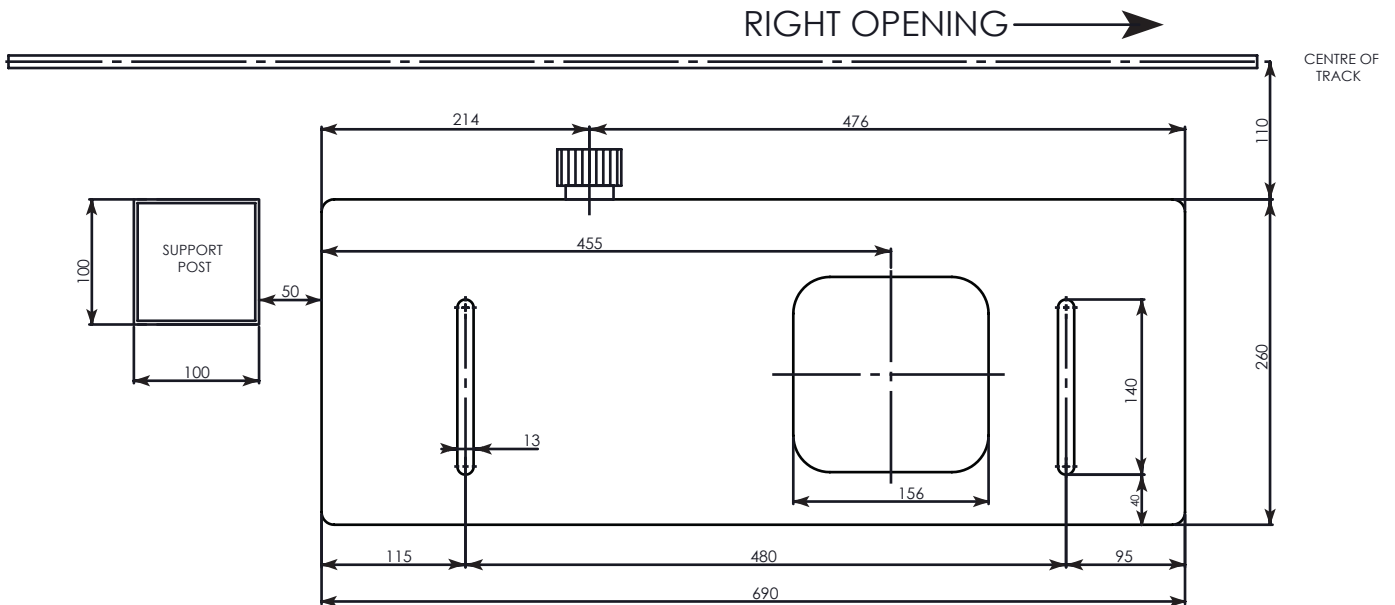

**Notes:**

- These measurements are only applicable when using a 100 x 100mm gate frame.
- This drawing is for a gate that opens to the right when looking from the non secure side of gate.

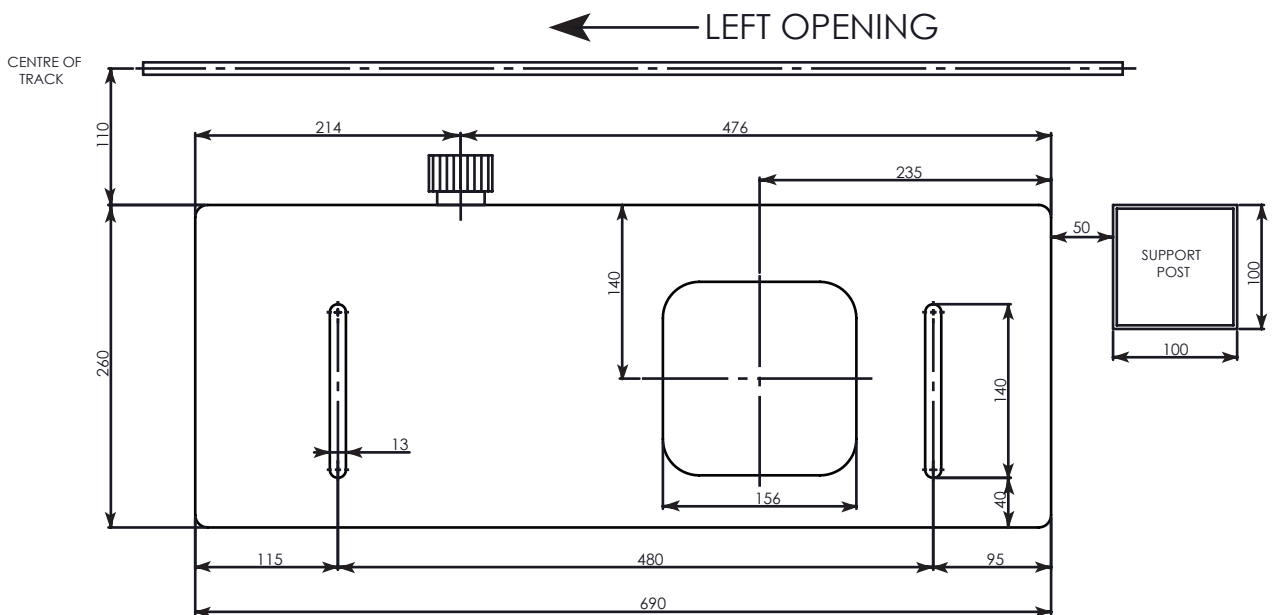

**Notes:**

- These measurements are only applicable when using a 100 x 100mm gate frame.
- This drawing is for a gate that opens to the left when looking from the non secure side of gate.

## GATE OPERATOR DIMENSIONS

### DA500/DA200

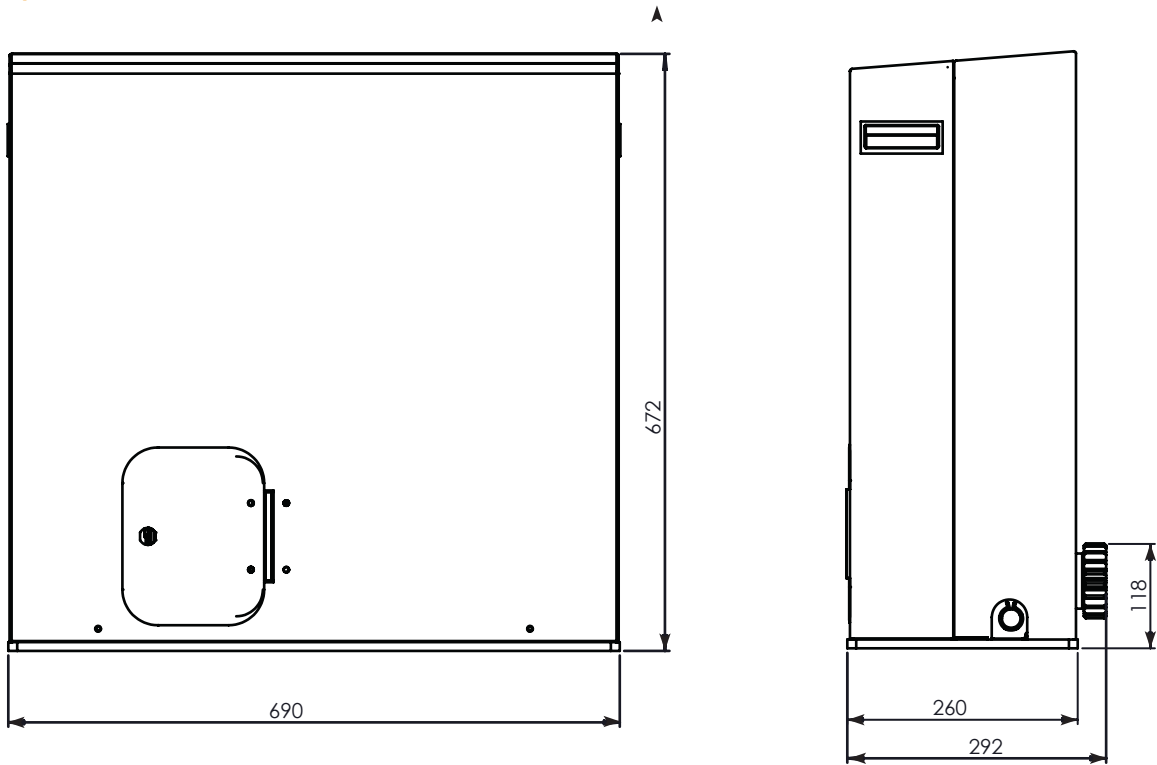

### DA700/DA250

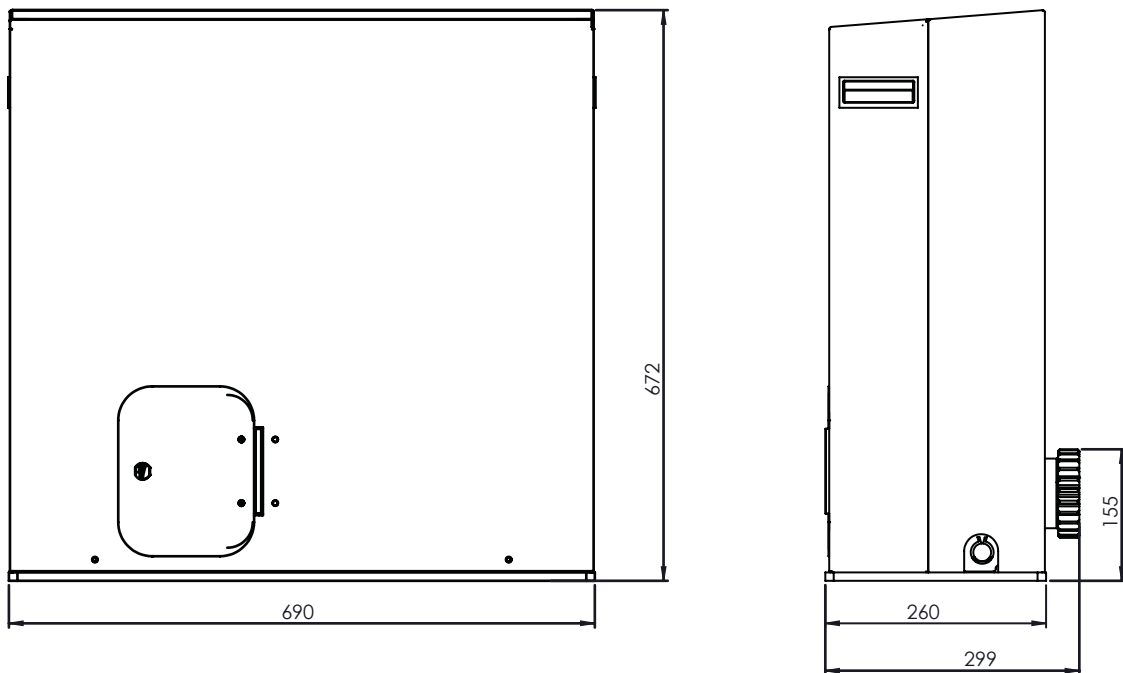

## INSTALLATION AND COMMISSIONING

After reading the previous sections in this manual and having checked for suitable installation, proceed as follows:

### Electrical Connection

1. Single phase 240VAC earth-leakage protected power with a suitably rated isolator should be available close to where the gate operator is to be mounted.
2. Connect the protected 10A 240V supply to terminals labelled A and N. Connect the earth wire from the power supply to the earth terminal in the operator control cabinet.
3. Conduits for power and control need to come up through the base plate 'knockout' if possible.
4. When bringing power and control cables into the control enclosure inside the operator, always leave enough slack in the cables, so the control system enclosure can be tilted up, to see and work on the controls more conveniently.
5. The control system enclosure can be tilted to simplify installation and maintenance. To tilt the enclosure, undo the wing nut on left hand side and move the bottom of the enclosure, until the unit is in the desired position. Once tilted, re-tighten the nut to keep enclosure in position. Always return the enclosure to the vertical position before operating the gate. To return the enclosure to the vertical position, undo the wing nut, gently lower the enclosure back down, and re-tighten wing nut.
6. See the installation manual for the Elsema MCi Control Board for connection of external inputs and set up details. Standard programming (motor brake and strobe light) has been performed in the factory and arrives ready to set limits and travel times.

Details can be found by scanning the QR code below or visit [www.elsema.com.au](http://www.elsema.com.au)





## FOR BI PARTING SLIDER CONFIGURATION ONLY

### Electrical Connections

1. 240V mains power is required on both sides of the driveway, as supply voltage is required for each operator. This can be achieved by either having 240V mains power available at each gate operator or directing 240V mains power across the driveway from the “Master” unit to the “Slave” unit.
2. A 6-core low voltage (24V) cable is also required from the “Master” unit to “Slave” unit, in addition to a Fig 8 cable for the Electric motor brake relay coil (12V).
3. Make the following low voltage connections within the “Slave” unit:
  - **Motor 2 Inverter:** Open, Close and COM
  - **Motor 2 Limits:** Open, Close and COM
  - **Brake Relay 2:** + & - (12V)

4. Connect the “Slave” unit to the “Master” unit as follows:

Connect cables from **Motor 2 Inverter** and **Motor 2 Limits** to the corresponding Elsema board terminals as labelled within the “Master” unit control box.

Connect the Fig 8 Motor brake coil cable (12V) to DIN rail terminals as labelled within both “Master” and “Slave” units.

All access control and safety devices must be connected to the “Master” unit control board.

### Commissioning

Press program button on Elsema board and select Learn menu, set up as a ‘Double’ and follow the learn prompts, as indicated on the control board display.

## Mechanical Installation

1. Ensure the gate rolls easily and smoothly through its entire travel and has been installed so that no excessive friction or binding occurs.

**IMPORTANT:** Ensure that gate stops have been firmly installed in the fully open and closed positions. These stops must be engineered and installed to stop the gate should the limits fail.

2. Ensure that the foundation on which the gate operator is to be mounted is flat, structurally sound, and of sufficient size to support the operator whilst in use.
3. Remove the cover from the gate operator and set aside.
4. Position the gate operator on the foundation in the approximate mounting location.
5. Use the rack to locate the operator the correct distance away from the gate rail (finer adjustment can be made once the rack has been installed on the gate).
6. Prepare to secure the gate operator to the foundation using four suitable 12mm x 100mm fasteners e.g. Dynabolts or chemical anchors. Two fasteners should be placed in each of the two mounting slots located at each end of the operator base plate. Positioning of the fasteners should allow for sufficient base plate adjustment. **Do not tighten these fasteners yet.**
7. Release the clutch by turning the knurled manual release knob anticlockwise to allow the drive gear to move freely.
8. Fix the rack to the gate rail ensuring there is a 1 to 2mm gap between the meshing of the teeth of the rack and drive gear (no more). Move the gate by hand from one end to the other while checking that the rack is meshing correctly with the drive gear on the operator. Check also that the rack is centred around the middle of the teeth on the drive cog– tighten the mounting plate nuts.

## Variable Speed Drive Unit

1. The variable speed drive unit controls the speed and acceleration of the gate. The gate will ramp up the speed of the operator and then ramp down prior to closing.
2. The slow-down limit switches must be set in a position that allows the gate to reach the slowdown speed before the gate reaches the fully closed position.
3. The acceleration (ramp up) and deceleration (ramp down) times and high and low speeds have been factory-set for a typical installation but can be changed if necessary.

**NOTE: Changing the speed or ramp times will change the position the gate will end up in its fully closed and open position. The limit switch cams must be adjusted after changing the gate speed or ramp times.**

Parameter	Description	Setting Range		Factory Setting		Gate Speed (mm/sec)			
		DA500/700	DA200/250	DA500/700	DA200/250	DA500	DA700	DA200	DA250
P100	Ramp up time	2 - 10 secs	2 - 10 secs	4 secs	4 secs				
P101	Ramp down time	2 - 10 secs	2.5 - 10 secs	2.5 secs	2.5 secs				
P124	Open speed	30 - 50 Hz	30 - 70 Hz	50 Hz	50 Hz	500	700	200	250
P125	Close speed	20 - 35 Hz	20 - 40 Hz	25 Hz	40 Hz	250	350	160	200
P126	Slow open speed	10 - 20 Hz	10 -20 Hz	10 Hz	20 Hz	100	140	80	100
P127	Slow close speed	10 - 20 Hz	10 -20 Hz	10 Hz	20 Hz	100	140	80	100

## COMMISSIONING

### Setting limits

The limit switches are in a yellow housing on the left-hand side of the operator, above the gearbox.

1. Remove the limit switch covers by unscrewing the four screws visible from the top.
2. Identify the cams and their adjusting screws. The adjusting screws are numbered on top of the cam tower. The adjusting screws are labelled 1 through 4 anticlockwise from the 7 O'clock position when viewed from the front of the operator:
  1. Top cam – Open limit
  2. Cam second from the top – Slow speed in opening
  3. Cam second from the bottom – Slow speed in closing.
  4. Bottom cam – Closed limit.

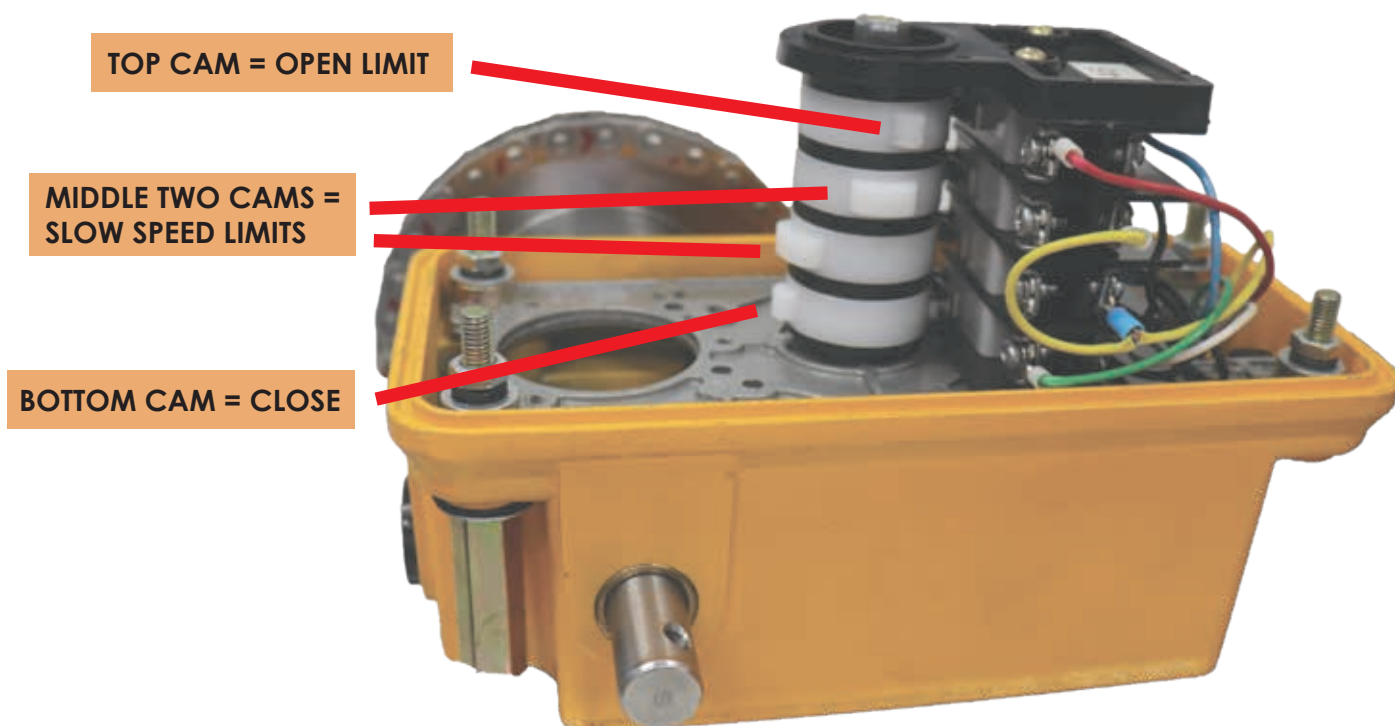

\*Note: It is important that the slow down limit is set to operate **before** the end of travel limit. This applies in both directions.

5. To adjust the cams:

1. Loosen the 8mm nut in the centre of the cam tower.



2. Follow the manual release instructions to release the clutch and allow the gate to be moved manually.
3. Manually move the gate to the fully closed position and observe the cam rotation. The close cam must move in the same direction as the cams were travelling.
4. Adjust the bottom cam using the adjustment screw labelled 4 on the cam tower to operate the micro switch just before the gate fully closes.
5. Adjust the cam second from the bottom using the adjustment screw labelled 3 on the cam tower so slow speed cam operates before the stop cam - as shown in photo.
6. Manually move the gate to the almost fully open position.
7. Adjust the top cam using the adjustment screw labelled 1 on the cam tower, so the cam rotates in the same direction and operates the microswitch.
8. Adjust the cam second from the top using the adjustment screw labelled 2 on the cam tower so this cam operates before the stop cam. This allows the gate to slow down before stopping.
9. Retighten (slightly) the 8mm nut locking nut on top of the cam tower once the cams are set to prevent movement.

## Control Board Setup

1. Power up the operator and allow the control board to run through its start-up procedure.
2. Select **Parameter 12—I learn** on the screen by turning the **Master Control** button.
3. Enter **I learn** mode by pressing the **Master Control** button.
4. Go through and answer questions on the screen
  - a. Gate
  - b. Single (Double)
  - c. Limit Switch
  - d. NC
5. Engage the clutch slightly by turning the knurled manual release knob clockwise. The clutch should be engaged just enough so the gate can drive.
6. Press the **Close Button** on the control board and check if the gate is closing.
  - a. If the gate is not closing, **turn off the power to the operator and wait for the inverter to deenergise, allow 10 minutes for safety.** Then swap any 2 phases on the inverter.
  - b. Turn the power back on and repeat the control board set-up.
7. Follow the screen prompts ie, press and hold Open Button until open limit operates.

NOTE: the gate will run at slow speed first, then at full open speed but will ramp down to slow speed once the slow speed cam is triggered.

8. When prompted by the screen on the control board, press and hold the Close Button until the gate reaches the fully closed position.

NOTE: the gate will run at slow speed first, then at full close speed but will drop to slow speed when the cam hits slow speed microswitch and stops at full closed position.

9. Learning successful - meaning travel time has been set for open and closed positions.
10. Check the operation of the gate and ensure all limit switches are adjusted and working correctly i.e. both slowing down and stopping the gate in the correct positions. The gate should move gently onto the open and closed stops. Driving the gate hard into stops will cause damage to the operator, gate and stops.
11. Check that all safety devices are operating correctly, e.g. Photoelectric beams, loops, strobes, bump strips, etc
12. Verify that the access control system is connected correctly and working.

## MANUAL RELEASE INSTRUCTIONS

1. Secure the gate firmly in position so it cannot inadvertently move, which may cause accidental damage or injury to property or person once the gate operator is released.
2. Open the small hinged door of the operator cabinet using the key and gain access to the manual release knob.
3. Turn the knurled knob anti-clockwise about half a turn to release the gate.



4. The gate can now be opened manually. Once it is in the open position, ensure the clutch is re-engaged or the gate is firmly secured by other means to prevent the gate from inadvertently moving, which may cause accidental damage or injury to property or person.
5. To re-engage the clutch, turn the knurled knob clockwise until it is very tight. If, when turning the knurled knob clockwise, it just spins, try spinning it clockwise with more force to release it off the hexagonal retaining nut OR hold the nut with one hand and turn the knurled knob clockwise with the other hand.

## MAINTENANCE DETAILS

**Warning: Failure to properly maintain equipment may result in injury or death, and damage to property and equipment**  
**Failure to follow the prescribed maintenance procedure may void the manufacturer's warranty.**

Recommended maintenance to be performed on the operator and gate are as follows:

Operator performs over 150 cycles per day:	every month
Operator performs between 100-150 cycles per day:	every 2 months
Operator performs between 50-99 cycles per day:	every 4 months
Operator performs between 20-49 cycles per day:	every 6 months
Operator performs under 20 cycles per day:	every 12 months

**NOTE: Chains on Chain Sliders must be oiled at least every two months.**

**Before** commencing maintenance on the gate or operator, isolate the electrical supply and ensure the system is de-energised.

Service performed by: \_\_\_\_\_

<b>DATE</b>	
<b>SITE NAME</b>	
<b>SITE ADDRESS</b>	

Gate rolls freely	
Gate wheels and guide rollers are in good condition	
Gate Stops are installed and in good condition, not loose	
Gate rack is tight and correct clearances between pinion wheel and rack	
Ensure gate chain, if fitted, is well-oiled and properly adjusted	
No oil leaks from gearboxes	
Gate Track is not damaged	
Gate operator bolts, fixings, grub screws tight	
Gearbox mounting bolts/nuts tight	
6 Month 'Baygon' type Surface Spray around operator and control box (not on electronics)	
Inside operator and control box clean	
All electrical connections tight	
Limit Switches operate in appropriate positions and limit-chain is lightly oiled	
External safety devices work effectively and are clean	
Electromagnetic lock, if fitted, operates correctly and is clean	
General operation i.e. speed, auto close etc normal	
Slightly grease worm drive on Limit switch	
Comments:	



## WARRANTY

1. Downee Pty Ltd Trading As Downee hereafter called Downee warrants that the goods manufactured by it shall be free from defect in manufacture for a period of 12 months from the date of invoice. Should any fault occur within that period as a result of faulty workmanship or materials, Downee will make all necessary repairs, or, at its discretion, replace the product at no charge to the customer except for installation and freight. The appropriate Serial Number must be quoted for all warranty claims.
2. For goods not manufactured by Downee, we shall pass on the manufacturer's warranty to the Customer from the date of invoice. It is the manufacturer's discretion to repair or replace goods deemed to be defective as a result of faulty workmanship or materials.
3. All goods must be returned to Downee or its representative for inspection and or testing to assess if a claim is justified. It is the responsibility and at the cost of the Customer, to return the goods for inspection and freight costs are the responsibility of the Customer.
4. The warranty is negated and will not apply in the following circumstances:-
  - i. If no proof of date of purchase can be produced
  - ii. If the product has been used in a manner beyond its design parameters.
  - iii. If the product is tampered with or repaired by personnel not authorised to do so.
  - iv. In respect of loss or damage caused by rough treatment
  - v. If the product is not used and maintained in accordance with instructions or recommendations listed in this Installation and Maintenance Manual.
  - vi. In respect of loss or damage caused by an Act of God or any other cause not within the manufacturer's control
5. Goods returned under warranty for repair or testing will incur a charge to be fixed by the manufacturer if no fault is found.
6. The Customer shall bear freight charges for removing and returning the goods for inspection and for the delivery and installation of any replacement or repaired product from a justified warranty claim.
7. Save for the express conditions and warranties herein contained all other conditions or warranties (whether as the quality, fitness for purpose or any other matter ) expressed or implied by statute, common law, equity, trade, custom, usage or otherwise are hereby expressly excluded provided that nothing in these terms and conditions shall exclude or limit any breach or condition implied by law, the exclusion or limitation of which is not permitted by law.